

SCB-16FA-IEPE

16 Channel Precision IEPE/Voltage Signal Conditioner



Description:

The Model SCB-16FA Signal Conditioner is a programmable 16-channel filter/amplifier with current source for Integrated Electronic Piezoelectric (IEPE) sensors and remote charge converters. The programmable IEPE source supplies 0 to 20 mA in 2 mA steps of current supporting all IEPE sensor types. Each channel input can be individually isolated to allow connection to grounded accelerometers without introducing ground loops. The IEPE current source disconnect mode allows the SCB-16FA-IEPE to be used as a 16-channel Precision AC Filter/Amplifier with balanced differential input.

A shift in the bias point of an IEPE sensor could be an indication that the sensor is beginning to fail, so measuring the bias point is a means of monitoring the sensor health. The SCB-16FA provides a readout of the bias voltage, as well as an 'out of range' indicator with user specified limits. In addition, sensor OPEN and SHORT indicators are provided.

Programmable channel gain and optional 4-pole FLAT/PULSE low-pass filters provide clean, amplified "data acquisition ready" output signals. The AC-coupled amplifier stage provides programmable gain settings up to x1000 in a x1, 2, 5, 10 sequence. The standard unit provides a 2-pole 100 kHz Butterworth low-pass filter with an optional 4-pole LP4FP FLAT/PULSE low-pass filter available in three standard ranges each with five programmable cutoff frequencies. A programmable wideband mode to bypass the filter is standard.

Packaged in a compact 1U rack mounted enclosure, the Model SCB-16FA front panel provides all the operators' interfaces including 16 input and 16 output BNC connectors, test and monitor bus BNC connectors, Ethernet connector with IP reset switch and status indicator, signal ground connector with ground source selection switch, power connector and power switch. The system is controlled using either the supplied graphic user interface or the remote command line interface.

Option F together with the SCB-7-TEST Test Subsystem adds Factory Acceptance Tests (FAT) capability to the SCB-16FA. The acceptance tests, initiated from the SCB GUI, are fully automated NIST traceable verification routines that measure and report the unit's performance as it relates to the published specifications.

The SCB-7-TEST consists of a third party digital multimeter and function generator, one BNC cable that connects the DMM to the SCB-16FA Monitor connector and a second BNC cable that connects the function generator to the SCB-16FA Test connector.

The Model SCB-16FA is powered by 10.8 to 30 VDC and is supplied with a tension clamp power entry mating connector. An external AC-to-DC universal supply is available from Precision Filters.

Specifications

Number of Channels: 16

Input Connectors:

16 Individual isolated BNC's at the front panel

Input Characteristics:

Input Impedance: 5 M Ω //100 pF per side

Max Level:

(AC+DC+Common Mode) ± 10 Vpk for $f \leq 200$ kHz
 ± 10 Vpk x (200 kHz/f) for $f > 200$ kHz

Input Protection:

30 V continuous (power on), 60 Vpk transient
(1 ms pulse, 50% duty cycle)

Noise: 15 nV/ $\sqrt{\text{Hz}}$ at 1 kHz and gain ≥ 100

AC Coupling Frequency (-3 dB): 0.5 Hz

CMRR:

100 dB DC to 440 Hz, gain ≥ 10 (Filter/Amp Mode);
80 dB DC to 440 Hz, gain ≥ 10 (IEPE Isolated Mode)

Test Input:

A switch at the channel input allows for injection of external test signal via an external front panel BNC connector.

Input Short:

Amplifier inputs may be programmed to ground to measure amplifier noise and DC offset.

MUTE Mode:

When the Mute button is ON, the channel is placed in the quietest quiescent state, minimizing the possibility of coupling noise on properly functioning channels from a faulty or failed sensor. Mute Mode is also useful for terminating unused channels in a safe and quiet state.

Specifications (Continued)

IEPE Current Source:

Programmable current source to power IEPE type transducers and remote charge converters. Current source may be disconnected under program control for standard filter/amplifier functionality.

Level:

Programmable 0 to 20 mA in 2 mA steps with current source disconnect

Accuracy: 0.1 mA, $\pm 5\%$ of setting

Sensor Connection:

Floating or grounded (programmable per channel) with open and short detection.

Compliance Level: 26 V $\pm 5\%$

Input Impedance (Current source connected):

>250 k Ω /100 pF per side

Sensor Bias Monitor:

Measurement of sensor bias voltage reported on command. The sensor bias detector measures the bias level and determines if it is within user defined limits. The bias level and status is indicated on GUI.

Amplifier and Filter:

Gain Settings:

1, 2, 5, 10, 20, 50, 100, 200, 500 and x1000 with pre-filter overload detection (10.2 Vpk threshold). Gain is distributed around filter for 2X out-band reserve.

Gain Accuracy: 0.1% at 1 kHz

Gain Temp Coefficient: 50 ppm/ $^{\circ}\text{C}$

Standard Low-Pass Filter:

Type:

2-pole Butterworth low-pass filter with $F_c = 100$ kHz (-3.01 db) and programmable bypass for wideband operation.

Optional LP4FP 4-Pole Low-Pass Filter:

Type:

4-pole, 4-zero FLAT/PULSE low-pass filter w/ programmable bypass for wideband operation. Programmable for maximally flat (LP4F) or linear phase with optimized pulse response (LP4P).

The LP4F is specified to have excellent pass-band flatness and sharp roll-off characteristics. The pass-band characteristic is nearly identical to a 4-pole Butterworth yet the LP4F has a much sharper roll-off. The LP4F is a good choice for applications such as spectral analysis and for anti-aliasing applications. The LP4P has excellent transient response and phase linearity making it a good filter for time domain applications including transient (shock) measurements and time domain waveform analysis. The LP4P has frequency

and time domain characteristics superior to the 4-pole Bessel filter.

Cutoff Frequencies:

FX01 Range: 100 Hz, 300 Hz, 1 kHz, 3 kHz, 10 kHz

FX02 Range: 300 Hz, 1 kHz, 3 kHz, 10 kHz, 30 kHz

Pass-Band Accuracy: (Standard and Optional LP4FP Filters)

± 0.1 dB, DC to F -0.1 dB

± 0.15 dB to F -0.5 dB

± 0.25 dB to F -3.01 dB

Phase Match:

0.1 $^{\circ}$ typical, 1 $^{\circ}$ max, DC to F -0.1 dB;

0.15 $^{\circ}$ typical, 1.5 $^{\circ}$ max to F -0.5 dB

Amplitude Match:

0.01 dB typical, 0.1 dB max, DC to F -0.1 dB;

0.015 dB typical, 0.15 dB max to F -0.5 dB

Bypass Bandwidth:

0 dB ± 0.1 dB to 100 kHz, -3 dB typical at 1.5 MHz

Spec	BU2 2-Pole Butterworth Low-Pass Filter	LP4F 4-Pole Maximally Flat Low-Pass Filter	LP4P 4-Pole Constant Time Delay Low-Pass Filter
Number of Poles	2	4	4
Amplitude @ Cutoff (Fc)	-3.01 dB	-3.01 dB	-3.01 dB
DC Gain	0.00 dB	0.00 dB	0.00 dB
Stop-Band Frequency (-80 dB)	100.00 Fc	5.9465 Fc	11.863 Fc
Phase @ Fc	-90 $^{\circ}$	-180.0 $^{\circ}$	-101.5 $^{\circ}$
Phase Distortion (DC to Fc)	<9.0 $^{\circ}$	<31.8 $^{\circ}$	<3.7 $^{\circ}$
Zero Frequency Group Delay	0.2251/Fc	0.4117/Fc	0.2920/Fc
Percent Overshoot	4.3%	11.1%	0.5%
1% Settling Time	1.05/Fc	1.65/Fc	0.66/Fc
0.1% Settling Time	1.20/Fc	2.72/Fc	0.77/Fc
-0.1 dB Frequency	0.391 Fc	0.635 Fc	0.182 Fc
-0.5 dB Frequency	0.591 Fc	0.775 Fc	0.406 Fc
-1 dB Frequency	0.713 Fc	0.849 Fc	0.574 Fc
-2 dB Frequency	0.875 Fc	0.937 Fc	0.813 Fc
-3.01 dB Frequency	1.000 Fc	1.000 Fc	1.000 Fc
-20 dB Frequency	3.165 Fc	1.741 Fc	3.025 Fc
-40 dB Frequency	10.00 Fc	2.956 Fc	5.693 Fc
-60 dB Frequency	31.62 Fc	4.599 Fc	9.098 Fc
-80 dB Frequency	100.0 Fc	5.947 Fc	11.86 Fc

Output:

Type: Single ended output

Output Connector: BNC per channel at front panel

Impedance: 10 Ω // 100 pF

Max Output: ± 10 Vpk, ± 10 mApk

Offset: <5 mV at any gain setting

Crosstalk: -90 dB, DC to 100 kHz

Noise: 5 μ Vrms RTI + 100 μ Vrms RTO; 3 Hz to 100 kHz

Output Voltage: ± 10 Vpk

Output Monitor:

A switch at the output of each channel allows for multiplexed connection to the chassis output monitor bus BNC connector for viewing any channel output with an external device.

NIST Traceable Self-Test (Option F):

All test and measurement systems require periodic calibration. Typically, this means dismantling systems and shipping components to an in-house cal lab or back to the manufacturer. Precision Filters' built-in test hardware and software let you leave the system in the rack and perform NIST traceable calibration tests on site. The test subsystem consists of the SCB graphical user interface (GUI), the SCB-16FA with option F installed, and the SCB-7-TEST third-party test instruments. For traceability, a high-performance digital multimeter (DMM) is kept in calibration by a third-party metrology test lab. Test software residing in the SCB GUI verifies calibration and traceability information of the DMM and then proceeds, step by step, through an extensive test routine. Every system function is exercised, and all data-critical performance characteristics are accurately measured and compared to published specifications. These calibration tests are the same rigorous measurement routines performed in the factory before shipment, and they serve as an excellent Factory Acceptance Test (FAT) to be used by a customer upon receipt of new equipment. The SCB FAT verifies all key performance characteristics including the following: Filter and amplifier frequency response, gain accuracy, AC coupling, noise, common-mode rejection ratio (CMRR), IEPE excitation and max signal level.

Control:

For local control, the SCB-16FA system is controlled via the front panel 10/100 Base T Ethernet interface using the supplied spreadsheet-style GUI application running on a Windows PC. The GUI supports control of all channel and system features and allows for group control of channels. Up to 8 systems in the SCB family can be controlled by a single GUI.

Alternatively, the system may be controlled remotely via a high level command line interface over Ethernet. All features and functions are available over the remote interface.

The settings are retained when the computer is disconnected even after a power cycle, allowing the unit to be pre-configured for an application in which a computer may not be available for control. A front panel reset button restores the IP address to factory default.

Physical:**Size:**

19" Rack mount, 10" Depth, 1U. Rack mounting ears included.

Weight: 4.6 lb. (net)

Operating Temp: 0 to 55°C

Storage Temp: -25 to 85°C

Humidity: 10% to 90% noncondensing

Power:

Power is supplied to the SCB-16FA from either a direct power source or via the optional SCB-ACDC-50W external AC to DC supply. A power supply mating connector is supplied with each SCB system.

Input: 10.8-30V DC

Power Consumption: 5W Max

Power Entry Connector:

3-pin pluggable tension clamp connector (one included with unit)

Ground:

A signal ground post is located on the front panel. A slider switch can connect signal ground to chassis ground for normal, ground referred operation. Alternatively the switch can be set to isolated mode to reference the SCB circuitry to an external ground connected to the signal ground post.

Isolation:

60 V DC or AC continuous bank isolation, signal ground to earth ground in isolated ground switch position.

Certifications:

CE, RoHS

Safety Standards: EN 61010-1

EMC Standards: EN 61326-1

Accessories:

CONN-IN-TCP3:

Spare 3-pin tension clamp mating power entry connector. One supplied with each system.

SCB-ACDC-50W:

External AC/DC power supply with 3-position tension clamp connector

SCB-7-TEST:

Test subsystem test instruments for Option F, Factory Acceptance Test (FAT). Contains the following components: Keysight 3458A 8-1/2 Digital Multimeter, 33509B Function/Waveform Generator, Rack Mount Kit, two four foot BNC cables and USB to GPIB adapter.

Ordering Information:

SCB-16FA-<100K-BU2|FX01-LP4FP|FX02-LP4FP>-IEPE-<F>

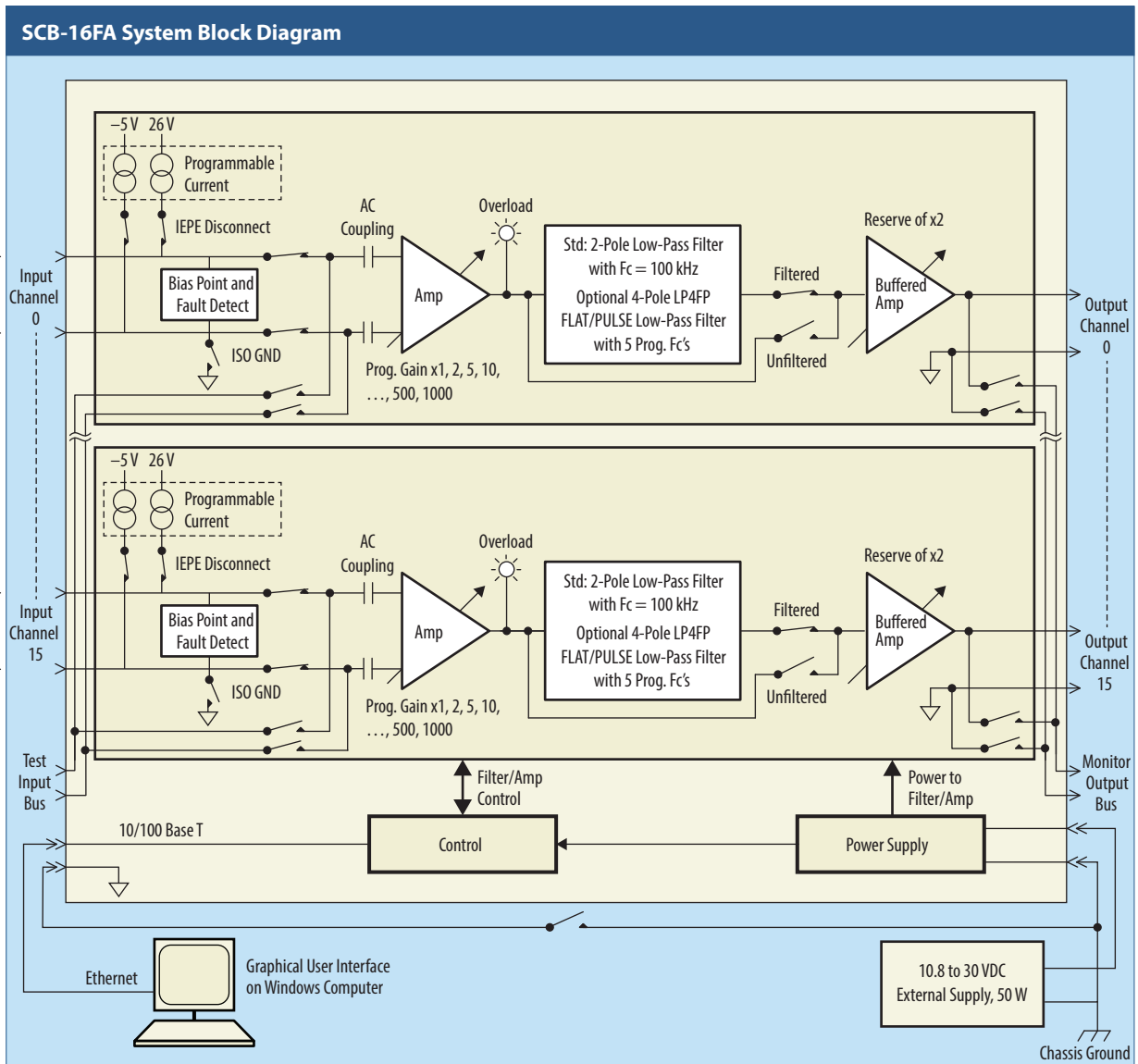
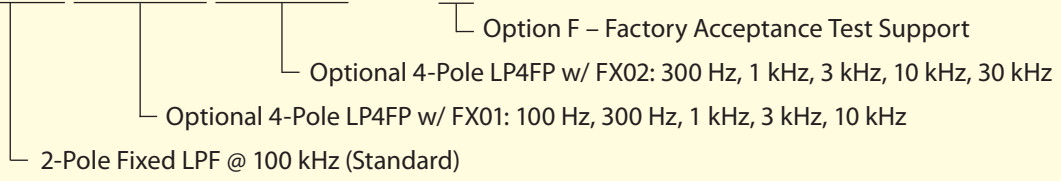

SCB-16FA System Block Diagram