

SCB-32CC-100 μ A

32 Channel Precision Constant Current Source for RTD, Thermistor or Silicon Diode Temperature Measurements



Description:

The SCB-32CC-100 μ A is a member of Precision's 1U family of rack mountable signal conditioners. The product provides a precise 100 μ A DC current source for measuring resistive transducers such as RTDs, thermistors or silicon diodes and is a suitable replacement for the obsolete National Instruments™ SCXI-1503.

You can make a 2, 3 or 4-wire connection to the SCB-32CC via the supplied plug-in 4-position spring clip connectors. Since the SCB-32CC does not contain a buffer, an external digitizer with a high-quality differential amplifier is recommended for lowest noise and best accuracy measurements. Packaged in a 1U rack mountable enclosure, the Model SCB-32CC front panel features all the operator interfaces including 32 sensor connectors, Ethernet connector with IP reset switch and status indicator, signal ground connector with ground source selection button, power entry connector and system power switch.

The high accuracy of the single-ended constant current source delivers a current level of 100 μ A with $\pm 0.03\%$ initial accuracy. Current flow to the load, voltage across the load and loop resistance are measured on demand using either the supplied graphical user interface (GUI) or the command line interface. The SCB-32CC has automatic calibration that can be run to optimize accuracy for a given ambient temperature. The optional Factory Acceptance Test (option F) allows the user to perform automated NIST traceable verification of system performance on-site with a third-party digital volt meter.

The Model SCB-32CC is powered by 10.8 to 30 VDC and is supplied with a screw terminal power entry connector. An external AC-to-DC universal supply is available.

Specifications

Number of Channels: 32 100 μ A constant current sources

Input Connectors:

Front panel mounted pluggable 4-position spring clip connections for 32 channels (supplied with unit)

Input Wiring: Excitation (2), Signal Ground (2)

Current Source Specifications:

Type: Single Ended Constant Current

Current Level: 100 μ A

Initial Accuracy: $\pm 0.03\%$

Drift: 10 PPM/ $^{\circ}$ C

Compliance: 10 V

Max Sensor Resistance: 100 k Ω

Spectral Noise: 2 pA per rt. Hz at 1 kHz

0.1-10 Hz Noise: 400 pA_{pk-pk}

Input Impedance: >100 M Ω

Current Source Regulation Bandwidth:

>100 kHz (-3dB) with 1000 Ohm Load

Protection: ± 30 Vpk

Sensor Health Monitor: On-demand measurement and reporting of current flowing to attached load, voltage across attached load, and sensor + cable resistance. Monitoring may be done during operation, as it does not affect current source performance.

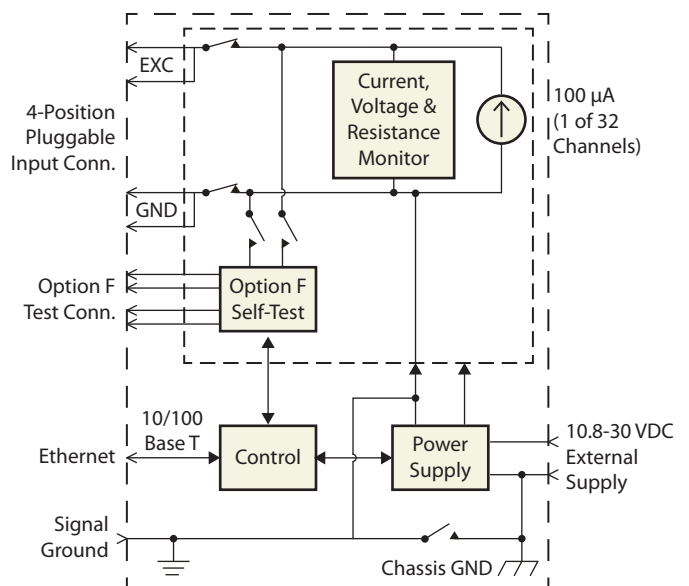

Block Diagram of SCB-32CC-100 μ A

Specifications (Continued)

NIST Traceable Self-Test (Option F): All test and measurement systems require periodic calibration. Typically, this means dismantling systems and shipping components to a cal lab or back to the manufacturer. Precision Filters' built-in test hardware and software let you leave the system in the rack and perform NIST traceable calibration tests on site.

The test subsystem consists of the SCB GUI, the SCB-32CC with option F installed, and the SCB-32CC-TEST third-party test instruments. For traceability, a high-performance digital multimeter (DMM) must be kept in calibration by a third-party metrology lab. Test software residing in the SCB GUI verifies calibration and traceability information of the DMM and then proceeds, step by step, through an extensive test routine. Every system function is exercised, and all data-critical performance characteristics are accurately measured with test uncertainty ratio (TUR) of four or greater and compared to published specifications. These calibration tests are the same rigorous measurement routines performed in the factory before shipment, and they serve as an excellent Factory Acceptance Test (FAT) to be used by a customer upon receipt of new equipment.

Control: The SCB-16FA system may be controlled via the front panel 10/100 Base T Ethernet interface using the supplied spreadsheet-style GUI application running on a Windows PC. The GUI supports control of all channel and system features and allows for group control of channels. Up to 8 systems in the SCB family can be controlled by a single GUI.

Alternatively, the system may be controlled remotely via a high level command line interface over Ethernet. All features and functions are available over the remote interface.

System settings can be retained in non-volatile memory allowing the unit to be pre-configured for an application in which a computer may not be available for control. A front panel reset button restores the IP address to factory default.

Physical:

Size: 19" x 10" x 1U (1.75") WxDxH

Weight: 4.75 lbs.

Operating Temp: 0 to 55°C

Storage Temp: -25 to 85°C

Humidity: 10% to 90% noncondensing

Power:

Input: 10.8-30 V DC

Power Consumption: 15 W Max

Power Entry Connector: 3-pin pluggable tension clamp connector (included with unit)

Ground: Signal ground post at front panel. Slider switch connects chassis ground to signal ground or isolates signal ground to accommodate external ground reference. Chassis ground is referenced to ground pin on power input connector. The slider switch position may be digitally read via the remote interface.

Isolation: 60 V DC or AC continuous bank isolation, signal ground slider switch in isolated position.

Certifications:

CE, ROHS

Safety Standards: EN 61010-1

EMC Standards: EN 61326-1

Accessories:

CONN-IN-TCP4: 4-pin tension clamp input mating connector for the sensor inputs (32 supplied with unit)

CONN-IN-TCP3: 3-pin tension clamp power entry connector (one supplied with unit)

SCB-ACDC-30W: External Power Supply with 3-position tension clamp connector.

SCB-32CC-TEST: Test Subsystem for Factory Acceptance Test (FAT). Includes Keysight 3458A Digital Multimeter, rack adapter, USB to GPIB adapter and test cable. SCB unit must be equipped Option F to run FAT.

CB-SCB-32CC-TEST: Test cable for FAT (One included with SCB-32CC-TEST test subsystem)

Ordering Information:

SCB-32CC-100 μ A-<F>

Option F – Factory
Acceptance Test Support