

Precision 28000 Test Subsystem For the 28000 Signal Conditioner

Performance verification is a critical part of ensuring data integrity of any measurement system.

A signal conditioner is a key component in the critical path of important test data, so its performance specifications must be rigorously proven and documented. At a minimum, yearly calibration helps to ensure defensible test data. But yearly calibration is costly, often requiring up to a month of downtime. And it's only the beginning. Making sure each channel works properly at test time means hours of tedious, difficult manual verification. The Precision 28000 self-test subsystem conducts rigorous yearly calibrations and quick Go/No-Go tests—all at the press of a button, and all without removing the system from the equipment rack.

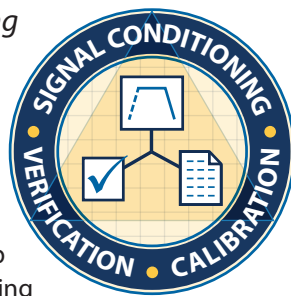

Precision 28000 Test Subsystem

The 28000 test subsystem is a complete solution to performing both annual equipment calibrations and run-time performance verification. The 28000 test subsystem supports a suite of tests that run on the instrument right where it is, with no need to disassemble or move it. The tests check out all critical system specifications, are NIST traceable, and are the same manufacturing tests that are run at the factory.

The 28000 test subsystem provides three levels of test. Pretest Verify and Diagnostics are used to confirm that all elements of the test subsystem are functional. The Factory Acceptance Test (FAT) performs a complete parametric performance check of the signal conditioners. Parameters such as common mode rejection ratio noise, offset, gain, frequency response, amplitude match,

and phase match are tested to original specifications. The Go/No-Go test does a quick check of the current programmed setup prior to an actual test to provide documented proof of system performance.

The same host computer controlling the 28000 system is used to control the test subsystem instruments. The GUI running on this computer controls all components necessary to run complete system tests. The 28000 channels are set to a desired test state, appropriate signal sources are selected, levels are programmed, and the multimeter (DMM) is read—all under computer control. One set of 28000-?-TEST test instruments can test multiple 28000 systems by daisy-chaining mainframes together. For traceability, the DMM is kept in calibration by a qualified metrology test lab.

System Features

- Fully automated Factory Acceptance Test for traceable periodic calibration
- Go/No-Go test for pretest verification
- Built-in 28000 test hardware provides multiplexors, attenuators, detectors, and other functions needed for stand-alone test without the need for external switches and other specialized hardware.
- Intuitive graphical user interface
- Third-party function generator and multimeter used for NIST traceability

System Benefits

- Built-in test hardware and software let you leave the system in the rack and perform NIST-traceable calibration tests at the test site.
- Every card function is exercised and all data-critical performance characteristics are accurately measured and compared to published specifications as required for traceable, defensible annual calibrations.
- Detailed test data reports provide traceability and statement of test uncertainties.
- Go/No-Go test quickly verifies the settings of each channel prior to the test run.

28000 Test Subsystem Components

The test subsystem consists of the 28000 graphical user interface (GUI), the 28000-BIF-FT backplane interface (BIF) card with option F installed, and the 28000-?-TEST third-party test instruments, along with 28000 signal conditioning card-specific cables and adapters.

28000 Graphical User Interface

The GUI software running on the host computer controls the 28000-BIF-FT backplane interface card and 28000-?-TEST test instruments. The GUI provides the necessary software modules to perform tests on all supported 28000 conditioner cards.

28000-BIF-FT Backplane Interface Card

The 28000-BIF-FT card (BIF) with option F is installed in each 28000 chassis. The BIF supplies control to 28000 signal conditioning cards and provides the necessary hardware to interface between the test subsystem instruments and the 28000 system internal test and monitor busses.

28000-?-TEST Test Subsystem Instruments

The 28000-?-TEST test subsystem consists of third-party test instruments to provide signal sources and precise measurement capability. A Keysight 33509B function generator is used as the source of the test signals. The 28000-5-TEST provides a Keysight 34465A 6.5 digit multimeter (DMM) for measurement capability. The 28000-7-TEST supplies a precision 8.5 digit 3458A DMM, required to test 28000 cards with high DC precision. In addition, the 28000-?-TEST includes a kit for rack mounting and cables necessary to connect the instruments to the 28000 test and monitor busses.



Keysight 33509B Function/Waveform Generator



Keysight 34465A High-Performance Multimeter

28000 Test Subsystem Description

Test Subsystem Control

The Precision 28000 test subsystem is controlled by a Windows host computer running the 28000 graphical user interface (GUI) software executable program. The GUI software controls the 28000-BIF-FT backplane interface card with option F and the 28000-?-TEST test instruments, typically over Ethernet. The BIF card provides communication and control support to the 28000 system and also contains the hardware interfaces to the 28000 test and monitor busses. Special hardware for test, such as synchronous detectors, amplifiers, attenuators, precise DC reference signals, and band-limiting noise filters are contained on the BIF in order to support the Factory Acceptance Test measurements.

The 28000 GUI FAT test selection panel allows the operator to select the channels and tests to perform on any hardware installed in the system. The GUI performs an inventory by model number and serial number of all equipment installed in the 28000 and includes this information in the reported test results. The model, serial, and trace numbers of the test instruments utilized are included in the test data files for traceability of the test data.

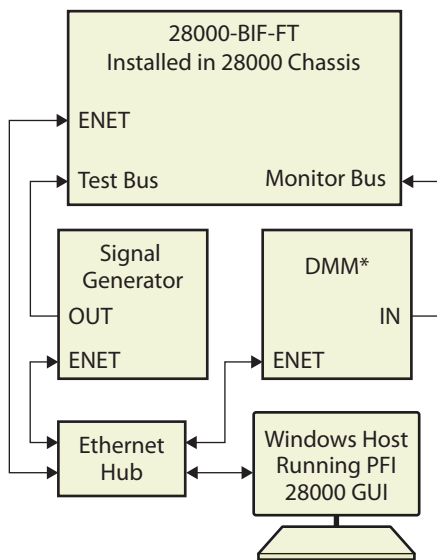

Block Diagram of 28000 Test Subsystem.

* The 3458A DMM (part of the 28000-7-TEST) requires a GPIB connection. A USB/GPIB adapter is supplied with the 28000-7-TEST Test Subsystem.

Levels of Tests

The 28000 test subsystem supports three levels of test:

- Go/No-Go Tests
- Factory Acceptance Tests
- Pretest Verify and Diagnostics

The FAT is an extensive test routine designed specifically for each card. Every card function is exercised, and all data-critical performance characteristics are accurately measured and compared to published specifications. These calibration tests are the same rigorous measurement routines performed in the factory before shipment and are intended for periodic traceable calibration of the 28000 system. In addition, they may be used by the customer upon receipt and acceptance of new equipment.

For a quick check of the equipment before a test run, the Go/No-Go test measures system performance of the current programmed 28000 system setup.

The Pretest Verify and Diagnostics routine confirms calibration and traceability information of the DMM and performs a comprehensive check that all test subsystem components are functioning properly. Running this routine is recommended prior to any FAT or Go/No-Go testing.

Test data results are reported as a summary report for the system, a complete listing of test results for the system, and an individual test report for each tested card in the system. Test conditions, measurements, tolerances, and pass/fail status are reported for each of the hundreds of unique FAT tests that are performed per card. The test data header file contains a statement of uncertainty and test uncertainty ratio for the hardware that is tested.

Factory Acceptance Tests

The Factory Acceptance Test (FAT) is a full parametric test and is normally run at regular maintenance intervals. All programmable settings of the channel are measured and compared to original factory specifications. The system operator can specify which channels are tested and which individual tests to perform. Test results are saved as text report files on the host computer.

Test report files include:

- Composite test data of all cards in the system
- Test data of each card
- Pass/Fail summary for each test performed on each card
- Error summary showing only failed test data for each card

Card FAT Tests

The Card FAT is a comprehensive set of Factory Acceptance Tests for signal conditioner cards. The user can select the channels to be tested and the tests to be performed.

FAT Tests Common to All Signal Conditioning Cards

- Common-mode rejection ratio (CMRR)
- AC/DC coupling
- Noise
- Filter frequency response
- Amplifier frequency response
- Channel-to-channel frequency response match
- Gain accuracy vs. programmed setting
- Offset voltage
- Linearity and maximum signal level
- Overload detector operation

Transducer Amplifier FAT Tests

- Current and voltage excitation
- Autobalance and zero suppress
- Resistive shunt calibration

Charge/IEPE FAT Tests

- Charge converter accuracy
- T-Insertion circuitry test
- IEPE current accuracy and noise
- Long-Distance TEDS circuitry test

Thermocouple Amplifier Tests

- Reference junction compensation tests

28000 Test Subsystem Description

FAT Tests for the Backplane Interface (BIF) Card

The BIF FAT test, for the 28000-BIF-FT card, tests all critical functions and programmable settings of the backplane interface card and functions of the test circuitry.

Selectable BIF FAT tests include:

- Test bus
- Monitor bus
- Synchronous detector measurement circuit
- A/D converter measurement circuit
- Precision DC reference accuracy
- Precision programmable attenuator accuracy
- Programmable monitor gain accuracy
- Programmable filter
- Frequency response
- Linearity and maximum signal level
- Internal temperature sensors
- Internal power supply voltages

Go/No-Go Tests

The Go/No-Go test provides a quick check of the system prior to taking data. Failed channels/cards are quickly identified so spares can be plugged in, minimizing system downtime.

The flexible Go/No-Go test routines allow you to select one or more tests (several tests are defined, including Filter, Gain, Offset, etc.), on one or more channels. The test confirms that the selected channel, or set of channels, is performing within specification of the selected test with the current channel setup.

The Go/No-Go tests include:

- Common-mode rejection ratio (CMRR)
- Programmed filter cutoff frequency accuracy
- Programmed amplifier gain accuracy
- DC offset voltage
- AC/DC coupling setting
- Linearity and maximum signal level
- Programmed excitation level
- IEPE current levels

Pretest Verify and Diagnostics

The Pretest Verify and Diagnostics routine confirms that test system components are functional and is typically run before Factory Acceptance Tests and Go/No-Go tests.

The following components are verified:

- Verification of test circuits on the 28000-BIF-FT card
- Verification of the function/waveform generator, digital multimeter, and monitor bus
- Verification of the 28000 test bus and monitor bus

Test Accessories

Monitor Bus and Test Bus Cables

Optional monitor bus and test bus cables are available to support additional cable length requirements and testing multi-chassis configurations.

Test Bus System Cables

Test bus system cables are coaxial BNC to BNC cables for connecting the 28000 front-panel TEST BUS connector and the Keysight 33509B function/waveform generator.

CB-BNC-24

24 inches (1 ea. included with 28000-?-TEST)

CB-BNC-48

48 inches

Test System Monitor Cables

Test system monitor cables are 9-pin D-shell to banana plug cables, with twisted shielded pair cable, for connecting the 28000 rear-panel SYSTEM MONITOR connector and the Keysight 34465A digital multimeter.

CB-DE9P/BAN-MONBUS-1.7

20 inches

CB-DE9P/BAN-MONBUS-4

48 inches (1 ea. included with 28000-?-TEST)

Test System Monitor Cables for Multi-Chassis Tests

Test system monitor cables for multi-chassis tests are 9-pin D-shell to 9-pin D-shell cables for daisy-chaining 28000 chassis using the additional SYSTEM MONITOR connectors on the rear of the chassis.

CB-DE9P/DE9D-2XMONBUS-1.7

20 inches

CB-DE9P/DE9D-2XMONBUS-4

48 inches

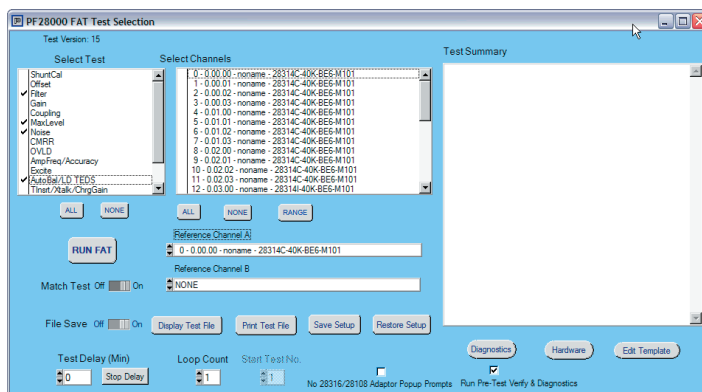

The FAT test selection panel allows the user to select any tests to run on any set of channels. Test results can be saved to a file for later retrieval. A test summary is listed for quick diagnosis.

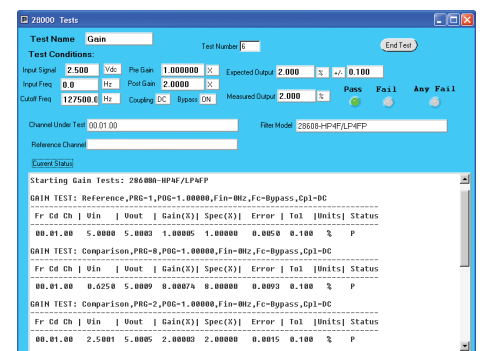

The FAT test screen reports the test conditions and provides a tabular listing of the test results during the execution of the test sequence.

Precision 28000 Test Subsystem

for the 28000 Signal Conditioner



Ordering Guide

28000-5-TEST: Test subsystem w/ Keysite 34465A (6.5 digit DMM), 33509B function generator, cables and rack adapters

28000-7-TEST: Test subsystem w/ Keysite 3458A (8.5 digit DMM), 33509B function generator, cables and rack adapters

28000-BIF-FT: 28000 backplane interface card with options FT for test subsystem hardware

28000 GUI: Included with 28000 system

Reference Cable for Match Testing: See table below

Card Specific Test Adapters: See table below

Test Adapter and Cable Requirements by 28000 Card Model					
Card Model	M3 Chassis Reference Cable for Frequency Response Match	M5 Chassis Reference Cable for Frequency Response Match	Required Test Adapter(s)	Test Adapter Function	Notes
28104A	CB-REF-C	CB-HD26P-REF-C	None	n/a	
28118 28108	CB-REF-C	CB-HD26P-REF-C	28108-TEST-ADAPTER	Supports test for excitation sense, current limit, linearity under load	1
28114 28144 28124	CB-REF-C	CB-HD26P-REF-C	28144-TEST-ADAPTER; CB-28144-TEST or 28124-HC10-TEST-ADAPTER; 28144-TEST-ADAPTER-3458A	Bridge completion, shunt cal, excitation sense, current limit, linearity under load	1
28124-EA	CB-REF-C	CB-HD26P-REF-C	28144-TEST-ADAPTER; 28144-TEST-ADAPTER-3458A	28124-HC10-TEST-ADAPTER, for cards with HC10 configuration modules only	1, 6
28154	CB-REF-C	CB-HD26P-REF-C	28144-TEST-ADAPTER; CB-28144-TEST or 28124-HC10-TEST-ADAPTER; 28144-TEST-ADAPTER-3458A	Bridge completion, shunt cal, excitation sense, current limit, linearity under load	1
28208	CB-REF-C	CB-HD26P-REF-C	None. 28208-ITB1 is required for FAT.	28124-HC10-TEST-ADAPTER, for cards with HC10 configuration modules only	1, 6
28302B	CB-REF-C	CB-HD26P-REF-C	28302B-CHARGE-ADAPTER	Supports traceable calibration of internal shunt capacitor	
28304 28324	CB-REF-C	CB-HD26P-REF-C	28304/28324-FAT-ADAPTER; 28000-TEDS-ADAPTER-A	Supports traceable calibration of internal shunt capacitor and optional TEDS functionality	2, 3
28314	CB-REF-C	CB-HD26P-REF-C	28334A/28314-CHARGE-ADAPTER; 28000-TEDS-ADAPTER-A	Supports traceable calibration of internal shunt capacitor and optional TEDS functionality	3, 4
28316C	CB-28316C-DC37P-REF-C	CB-28316C-DC37P-REF-C	28316B-TEST-ADAPTER-A or 28316B-IEPE-ADAPTER	Required for IEPE current accuracy and optional TEDS functionality	5
28454A	CB-REF-C	CB-HD26P-REF-C	None	n/a	
28458	CB-REF-C	CB-HD26P-REF-C	CB-28458-TEST	Supports traceable calibration of internal reference resistor for excitation current measurements	
28524	CB-REF-C	CB-HD26P-REF-C	None	n/a	
28618 28608B	Match not supported	Match not supported	None	n/a	
28612	Match not supported	Match not supported	None	n/a	
28000-OM-TEST	n/a	n/a	Requires proper test cable for output adapter module to be tested. Consult factory.	The test card occupies two slots of a 28000 chassis and interfaces to the 28000 test subsystem to provide automated testing of 28000 output adapter modules.	

Notes 1: Minimum of two adapters required per system. Two adapters per card strongly recommended for test time reduction.

Notes 2: One 28304/28324-FAT-ADAPTER required per system.

Notes 3: One 28000-TEDS-ADAPTER-A required per system. Two adapters per card strongly recommended for test time reduction.

Notes 4: One 28334A/28314-CHARGE-ADAPTER required per system.

Notes 5: Select only one adapter. The 28316B-TEST-ADAPTER-A is required for units with the TEDS option. The 28316B-IEPE-ADAPTER is required for units without the TEDS options. Two adapters per card strongly recommended for test time reduction.

Note 6: The 28000-7-TEST is required for this card model.



P8492 Rev B

Precision Filters, Inc.
240 Cherry Street
Ithaca, New York 14850

Telephone: 607-277-3550
E-mail: pfinfo@pfinc.com
Web Site: www.pfinc.com